

Advantages of circulation filtration:

Separation of the dirt from the water using flow energy. Large dirt-discharging capacity at minimal loss of flushing water.
Well-adjusted inflow keeps the filter element clean.

Advantages of UDI circukon filters:

The combination of steel strength and resistant plastic allows for a wide range of applications. The **UDI** circukon filter has a PVC filter element with a stainless steel filter screen of 75 to 800 microns.

Dirt is continuously being collected during operation, thus avoiding an increase in the differential pressure. This is achieved by using a specially designed whirl plate with four obliquely drilled-in holes.

By removing or adding plugs, the flow velocity can be optimised.

Due to the large difference in flow rate per hole, the filters are suitable for many applications.

The entire filter area is optimally used, due to a uniquely designed spiral groove under the filter mesh.

The dirt collection chamber is a component of the filter element. The conical inlet prevents backflow of the dirt. The filter cover is light and easy to handle.

Discharging dirt can be automated in a simple manner.

To increase the dirt-discharging capacity, the filter can be applied cross-flow.

All models can be modularly interconnected to form units of any shape and capacity, if necessary with a joint dirt-discharge tank.

A comprehensive range of fittings, connectors, and rapid couplings of the same make is available for assembling the units.

A stainless steel version of the filter is optionally available.



Coating:

In preparation for the coating to be applied, the filters are provided with a special layer of zinc phosphate. This treatment ensures proper adhesion of the coating, and protects against rusting-through from the inside. Subsequently, the polyester coating is applied electrostatically, both internally and externally, before being furnace-hardened. The entire process involves 7 steps, and results in a perfect coating with a thickness of approximately 120 microns.

Model:

In-line filter body, downwards pointing collection chamber in the filter element.

Applications:

- Recirculation systems
- Cooling water processes
- Washing water purification food industry
- Basin water filtration
- Irrigation systems

Technical specifications:

- Max pressure: 10 bar
- Working pressure: 8 bar
- Recommended ΔP : 0.25 - 0.5 bar
- Flushing water 2 - 5 litres
- Ph 5 - 9 resistant

Materials:

- Polyester-coated steel
- Neoprene rubbers
- Nylon whirl plate
- PVC filter element with stainless steel filter screen

Perforation: 75, 100, 130, 200, 300, 435, and 800 microns (other perforations upon request)

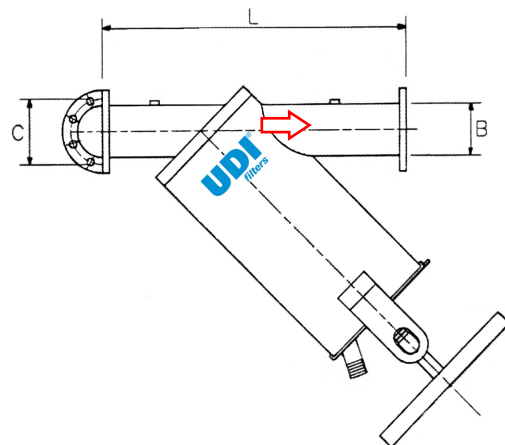

| Type | Unit | 4U8015F | 4U8020F | 4U8030F | 4U8040F | 4U8060F | 4U8080F | 4U8090F |
|----------------------------|-------------------|----------------------|----------------------|----------------------|----------------------|----------------------|----------------------|-----------------------|
| Connection \varnothing B | inch | 1,5" | 2" | 3" | 4" | 6" | 8" | 10" |
| Capacity | m ³ /h | 4,5 - 13 | 9 - 25 | 16,5 - 45 | 27 - 75 | 55 - 150 | 165 - 300 | 270 - 500 |
| Flange (ISO 7005 PN10) | | | | | | | | |
| Connection \varnothing B | mm | 40 | 50 | 80 | 100 | 150 | 200 | 250 |
| Diameter | mm | 150 | 165 | 200 | 220 | 285 | 340 | 405 |
| Pitch C | mm | 110 | 125 | 160 | 180 | 240 | 295 | 350 |
| Holes | mm | 4 x \varnothing 18 | 4 x \varnothing 18 | 8 x \varnothing 18 | 8 x \varnothing 18 | 8 x \varnothing 22 | 8 x \varnothing 22 | 12 x \varnothing 22 |
| Overall length L | mm | 430 | 410 | 535 | 565 | 740 | 875 | 1195 |
| Weight | kg | 16 | 17 | 29 | 35 | 56 | 130 | 175 |